

# ROTATING HF

## Semi-automatic self-cleaning filter



Semi-automatic self-cleaning filters. Cyclone operation with helical flow in service. It is supplied with: 360° rotating head, brass plug connections with incorporated non-return valve, plastic body reinforced with fibreglass, stainless steel cartridge with helical system, transparent vessel, semi-automatic drain for backwash and maintenance calendar. Special for both in line and vertical connections. It is a cutting edge device in the field of self-cleaning semi-automatic cyclone filters since, in addition to draining the dirt collected, with its backwash it makes sure the filter cartridge is effectively and properly cleaned. To clean the filtering element simply open the drain on the bottom of the vessel; this simple operation activates the backwash system. Each time the drain is operated the following system is activated: water filtration for washing + automatic draining + automatic backwash. The structure of the filter tends to convey the dirt to the bottom of the vessel through a cyclone effect, thus facilitating accumulation of the filtered material on the bottom of the vessel. Including key for removing/opening the vessel.

CODE	MODEL	MATERIAL			CAPACITY (ΔP=0,2BAR) Lt/min	PN BAR	CONNECTIONS	DIMENSIONS IN MM		STANDARD FILTERING CAPACITY MICRON	MAX. WATER TEMP. °C
		HEAD	VESSEL	CARTRIDGE				A	B		
HF000034	HF ¾"	PPGF30	PMMA	S. steel	40	12	¾" M	195	335	60	65
HF000001	HF 1"	PPGF30	PMMA	S. steel	58	12	1" M	187	335	60	65
HF000014	HF 1¼"	PPGF30	PMMA	S. steel	70	12	1¼" M	210	335	60	65

HOT WATER VERSION AVAILABLE UPON REQUEST

**ACCESSORIES:**

CODE	DESCRIPTION
TIMERWA1	timer wash, automation with variable program, including solenoid valve. Specify combined filter in the order (for HF Filter).

**SPARE PARTS:**  
p. 18-19

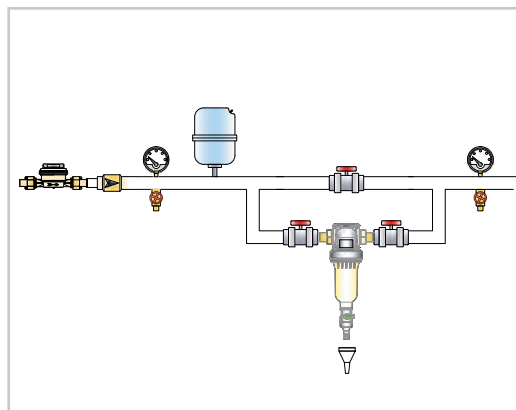

INSTALLATION

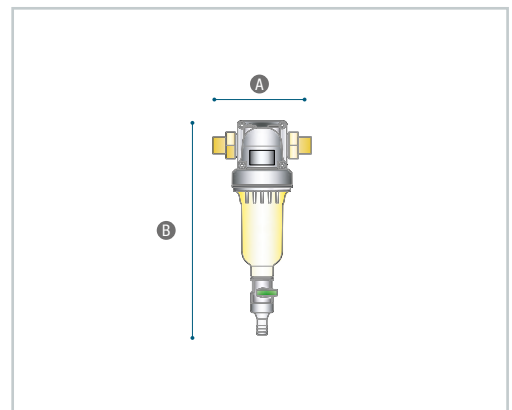

DIMENSION